

Figure 7-11 Wire mesh tie at wall intersection does not transfer loads.

deformation reduces their strength in transferring lateral loads. Crimped ties, in fact, are prohibited under some building codes because their compressive strength is only about half that of uncrimped ties. Drips are incorporated by some manufacturers by installing a plastic ring at the midsection of the wire.

Many building codes prescribe maximum tie spacing. Ties should be staggered so that no two alternate courses form a continuous vertical line, and ties should always be placed in the mortar bed rather than laid directly on the masonry unit. Structural requirements of metal wall ties can be calculated by rational design methods. Particularly in the case of adjustable ties in load-bearing construction, it is recommended that engineering analysis be used to assure adequate strength and proper performance. Adjustable ties for cavity walls should be structurally designed for each different condition of wind load, tie configuration, dimension, size, location, stiffness, embedment, modulus of elasticity of masonry, moment of inertia of each cavity wall wythe, and difference in level of connected joints.

Wire ties may be rectangular or Z shaped, in lengths of 4, 6, or 8 in. (see Fig. 7-12). Z-ties should have at least a 2-in. 90° leg at each end. Rectangular ties should have a minimum width of 2 in. and welded ends if the width is less than 3 in. Either type may be used for solid masonry (core area less than 25%), but Z-ties are less expensive. Only rectangular ties should be used in ungrouted walls of hollow masonry. Corrugated steel ties should have 0.3- to 0.5-in. wavelength, 0.06- to 0.10-in. amplitude, 3/8-in. width, and minimum 22-gauge thickness. Corrugated ties should be long enough to reach the outer face shell mortar bed of hollow units or the center of the mortar bed for solid units. Wire mesh ties should be formed of unwelded, woven wire, 16 gauge or heavier. A minimum width of 4 in. is required and a 1/2- × 1/2-in. or finer mesh. Lengths may be field cut for convenience, and butt joints are acceptable.

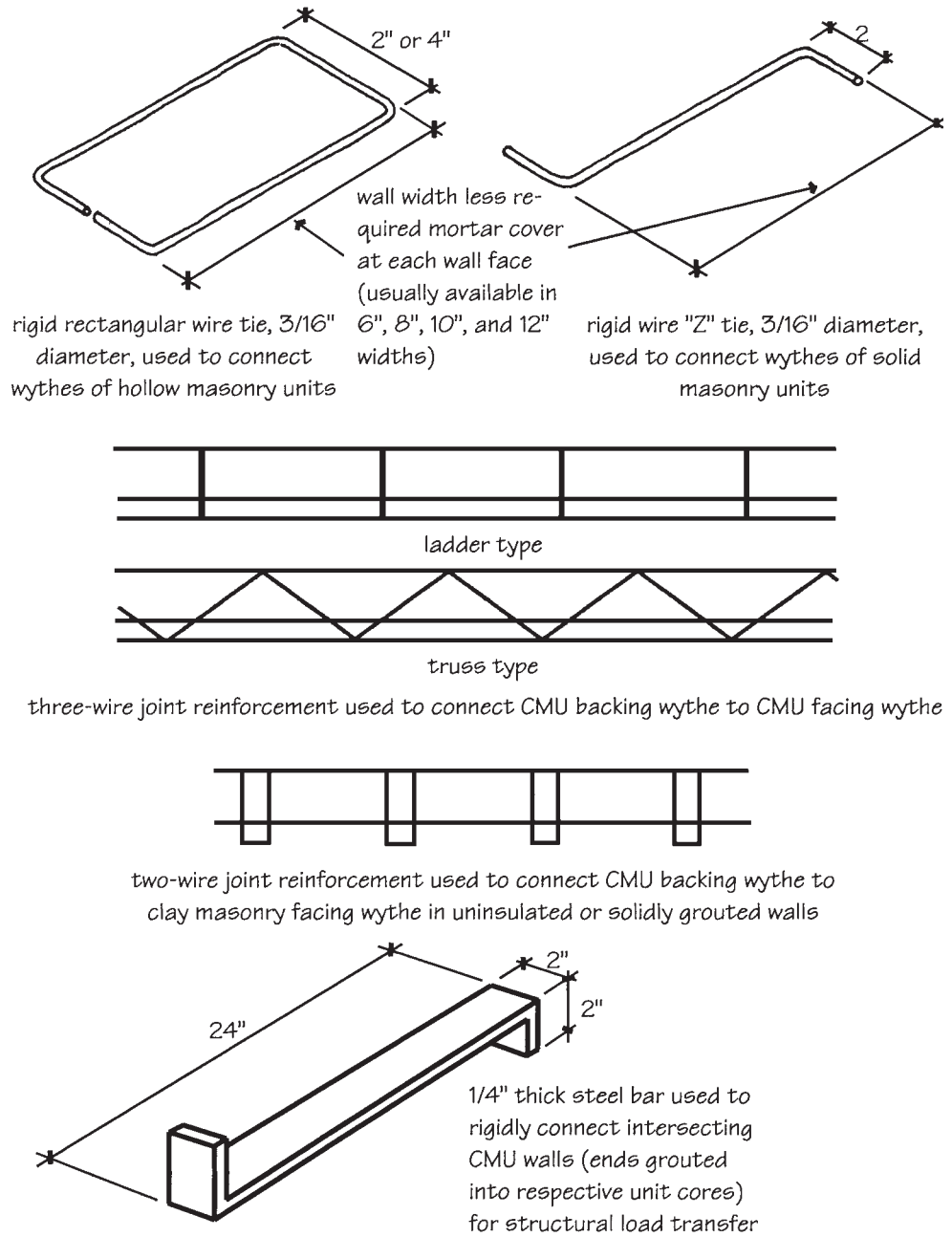

Figure 7-12 Rigid masonry ties.

Although metal ties are typically made of several materials, highest performance results from the following:

- Stainless steel, ASTM A167, Series 300
- Carbon steel, hot-dip galvanized after fabrication in accordance with ASTM A153, Class B2, and as follows:
 - Steel plate, headed and bent bar ties, ASTM A36
 - Sheet metal, ASTM A366